

1.4 Coarse threaded studs

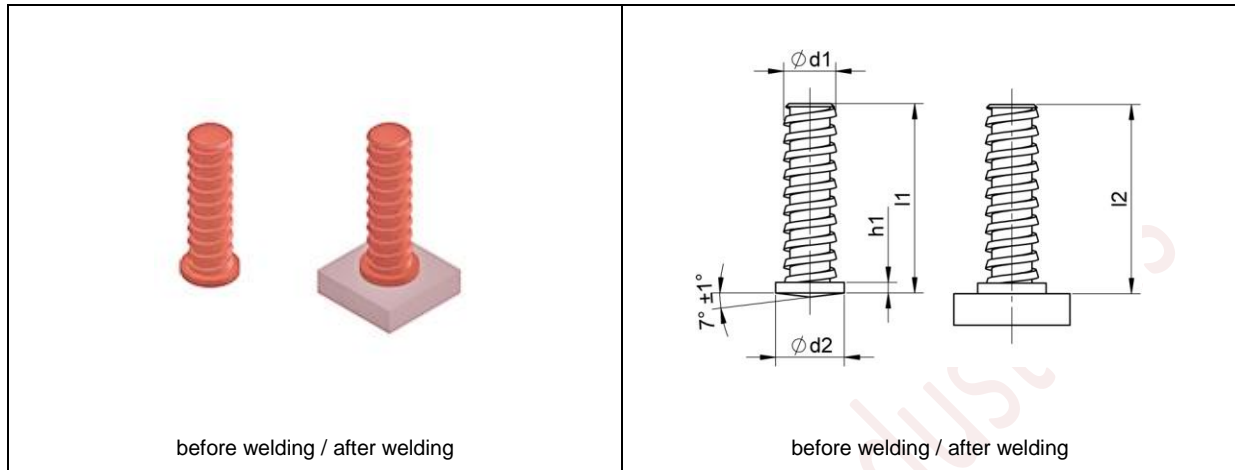

d1	l1 +0.6	d2 ±0.2	h1	l2
5	9	6.5	0.7-1.4	≈ l1-0.3
5	14.2	6.5	0.7-1.4	≈ l1-0.3
5	18	6.5	0.7-1.4	≈ l1-0.3
5	25	6.5	0.7-1.4	≈ l1-0.3

- Dimensions that are not listed in the measurement tables are delivered on request.